

Precision SMU

S2013C

 [Datasheet](#) V1.7

Based on bidirectional switching power supply and digital control loop technologies, the S2013C achieves precise and rapid output characteristics while significantly reducing module size. It complies with PXIe standard, is compatible with existing mainstream PXIe chassis, features high integration, and enables multi-module synchronization testing. It provides ± 200 V, ± 1 A (DC), and ± 3 A (pulsed) output with a constant power of 20 W, a maximum sampling rate of 1 Msps, and a minimum measurement resolution of 100 fA/100 nV.



Contents

1	Product Description	4
2	Features and Benefits	5
	APFC System	5
	Maximum Range	5
	Minimum Measurement Resolution	5
	High-Speed Measurement	6
	Sensing Mode	6
	Sweep Mode	6
	Auto Ranging	7
	Source Delay	7
	Protection	7
	Synchronous Triggering	8
	Free PC-Based GUI Control Software	9
	PC System Configuration	9
3	Specifications	10
	SMU Output Capability	11
	Voltage Programming and Measurement Resolution/Accuracy	12
	Current Programming and Measurement Resolution/Accuracy	13
	Resistance Measurement Resolution/Accuracy (4-Wire)	14
	Pulse Source Specifications	15
	Pulse Source Rise Time	16
	Output Settling Time	17
	Sampling Rate and NPLC Setting	17



Measurement Accuracy Derating18
Environmental Specifications18
4 Ordering Information 19
5 Warranty.....20



1 Product Description

The Semight S2013C is a compact and cost-effective, single-slot, single-channel PXIe Source/Measure Unit (SMU) with the capability to source and measure both voltage and current. It delivers output up to $\pm 200\text{ V}$, $\pm 1\text{ A}$ (DC), and $\pm 3\text{ A}$ (pulsed) with a constant power of 20 W and supports conventional SMU SCPI commands for easy test code migration. Compatible with existing mainstream PXIe chassis, it offers high integration, enabling easy channel expansion and multi-module synchronization. These features improve efficiency and lower the cost when integrating the SMUs into systems for production test.

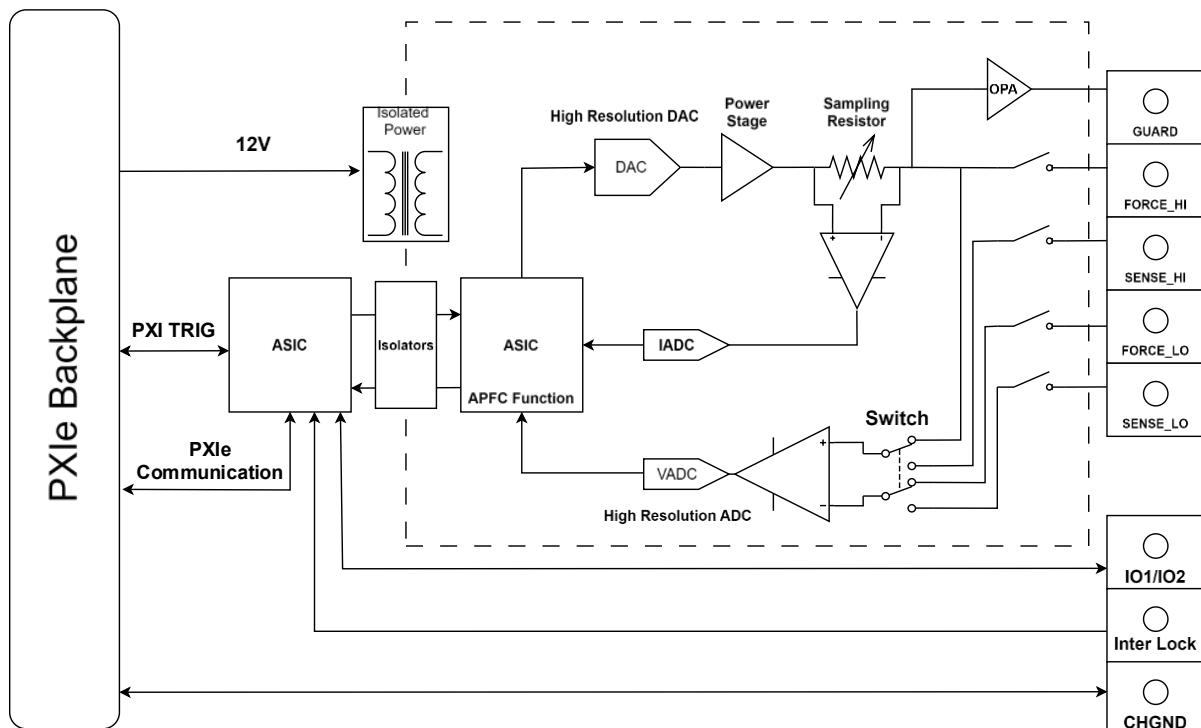

S2013C Block Diagram



2 Features and Benefits

APFC System

Supports user modification of APFC (Adaptive Precision-Fast Control) parameters. Users can adjust the parameters based on load characteristics to achieve precise and rapid output characteristics.



Waveforms Comparison Before and After APFC Adjustment

Maximum Range

Output range: ± 200 V, ± 1 A (DC), ± 3 A (pulsed). Dual modules enable easy LIV sweep testing.

Minimum Measurement Resolution

Current and voltage measurement resolution down to 100 fA/100 nV. Can make low-level measurements using a low-cost PXIe SMU that were previously only possible using a more expensive semiconductor device analyzer.



High-Speed Measurement

ADC sampling rates up to 1 Msps, with selectable NPLC (Number of Power Line Cycles) and sampling rate.

Sensing Mode

Supports 2-wire or 4-wire (remote-sensing) connections. Maximum sense lead resistance is 1 K Ω (for rated accuracy). Maximum voltage between output and sense terminals is 2 V.

Sweep Mode

Supports linear, logarithmic, and list sweeps in both single and double directions. The step interval is configurable from 1 μ s to 16 s, with a maximum of 10⁶ points per sweep.

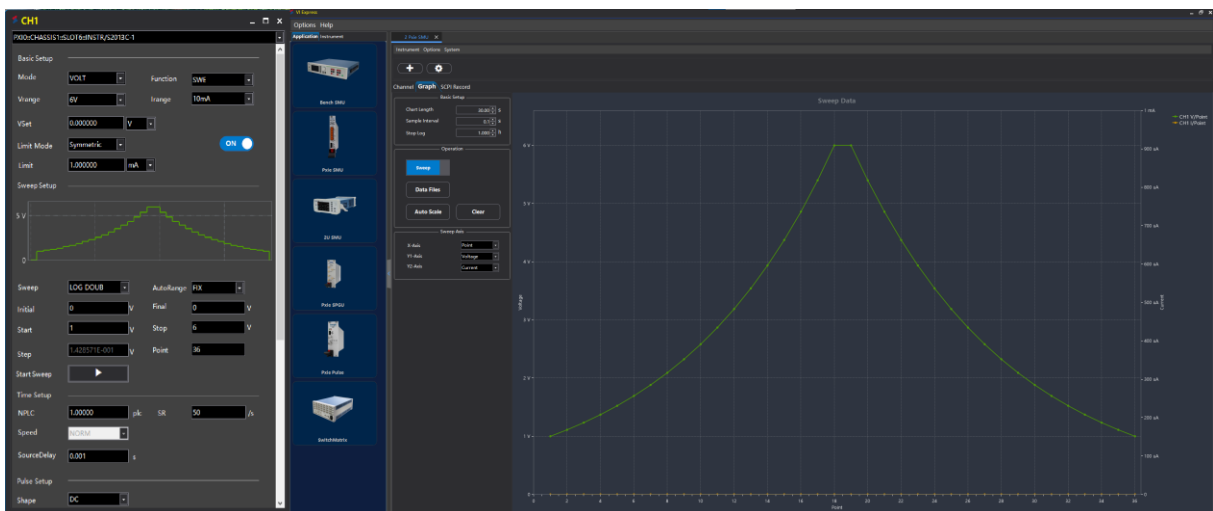

Double Logarithmic Sweep



Auto Ranging

Supports auto-ranging for both spot and sweep measurement. For overshoot-sensitive devices, it is recommended to turn off the output before switching ranges.

Source Delay

Supports Source Delay measurement. Users are recommended to set an appropriate Source Delay for more accurate measurements. Source Delay must exceed the source settling time, especially for low current ranges. When the sampling values are inaccurate, it is necessary to consider whether the Source Delay is appropriately set.

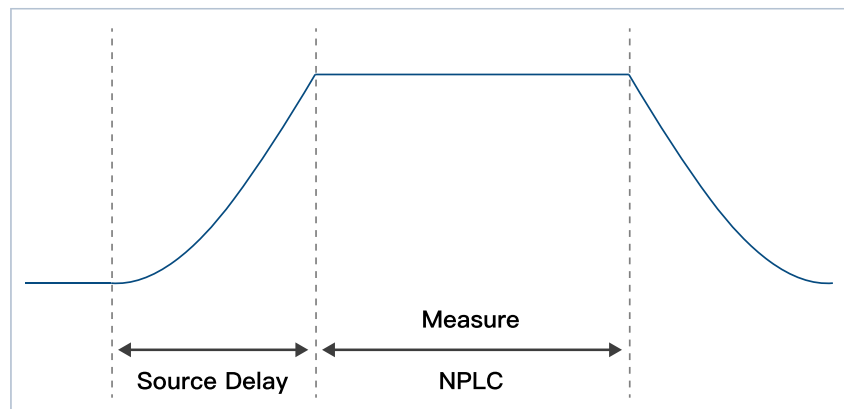

Source Delay and NPLC Setting Diagram

Protection

- Over-temperature protection: The system power shuts down at over temperature sensed internally.
- Over-current and over-voltage protection: If triggered, the module LED turns red, then operation resumes after a hardware reset command or power cycling.
- If the module LED fails to light, a problem may exist with a hardware module.



Synchronous Triggering

- Supports multi-module synchronous triggering using both internal (8 Trig Bus lines, 0 to 7) and external (2 Digital I/O lines, 1 to 2) trigger sources. Configure the internal Trig I/O to ensure all modules are on the same routing segment within the chassis. If not, the internal Trig I/O can be routed to the corresponding I/O via the chassis host software.
- The following principles must be adhered to for both internal and external triggering: A channel can be configured with multiple I/O ports for trigger output, but only a single I/O port can be configured for trigger input at any given time; An I/O port can be configured as a trigger input for multiple channels, but it can only be configured as a trigger output for one channel at any given time.
- Pulse width: 100 ns to 1 ms (configurable); Active high.
- External DIO trigger level:

DIO Parameters	Max Rating Value
Absolute Maximum Input Voltage	5.25 V
Absolute Minimum Input Voltage	-0.25 V
Minimum Logic High Level	2.1 V
Maximum Logic Low Level	0.7 V
Maximum Logic Output Current	2 mA
Maximum Sink Current	-50 mA



Free PC-Based GUI Control Software

Can make measurements and control remotely from a PC without the need to program.

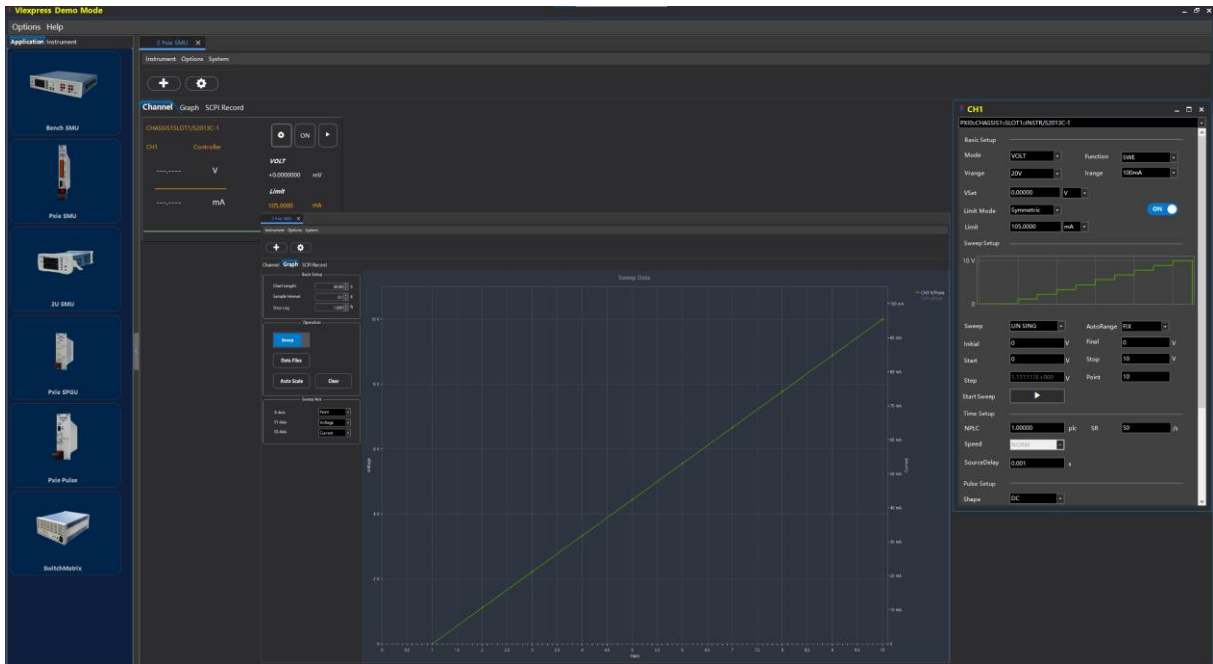

Software GUI

PC System Configuration

- Intel Core i7 or higher.
- Minimal 8 GB memory (additional memory required based on actual application).
- Windows 11 / Windows 10 (64-bit) / Windows 7 (64-bit, with required patches for driver installation).
- Installation of the Semight driver is required to configure and operate the module.



3 Specifications

Operating Conditions:

- Temperature: $23\text{ °C} \pm 5\text{ °C}$.
- Humidity: 30% to 60% (RH).
- Measure after a 60-minute warm-up; Ambient temperature change less than $\pm 3\text{ °C}$ during measurement.
- Calibration period: 1 year.
- Measurement speed: 1 PLC (power line cycle).
- Fans set to the highest setting if the PXIe chassis has multiple fan speed settings.



SMU Output Capability

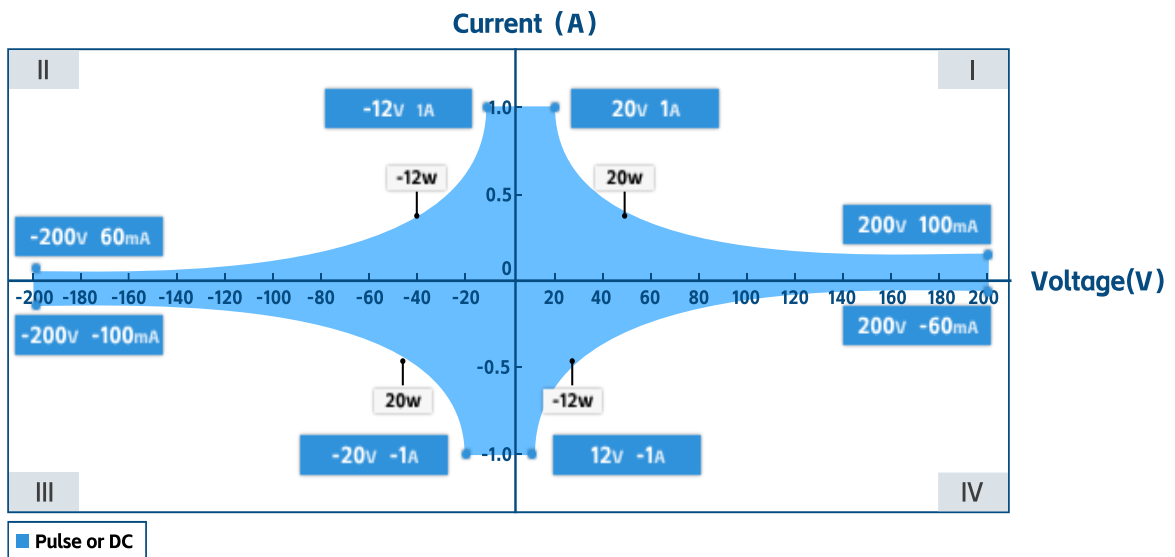

DC I-V Output Capability

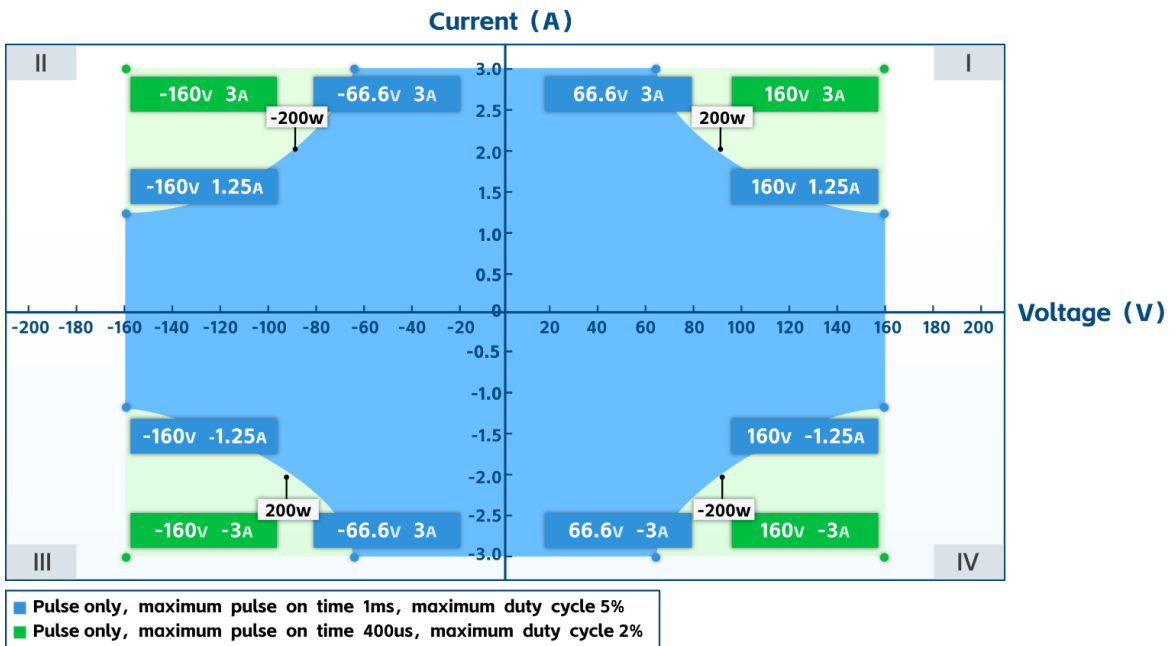

Pulse I-V Output Capability



Voltage Programming and Measurement Resolution/Accuracy

	Range	Resolution	Accuracy (1 Year) ± (% reading + offset) ^[1]	Typical Noise (RMS) 0.1 Hz to 10 Hz
Voltage Accuracy	±200 V ^[2]	100 µV	0.03% + 10 mV	400 µV
	±20 V	10 µV	0.03% + 1 mV	50 µV
	±6 V	1 µV	0.03% + 0.4 mV	12 µV
	±0.6 V	100 nV	0.03% + 100 µV	3 µV
Temperature Coefficient	± (0.15 × accuracy)/°C (0 °C to 18 °C, 28 °C to 50 °C)			
Overshoot	< ±0.1% (Typical, Normal; Step is 10% to 90% range, full-scale, resistive load)			
Noise 10 Hz to 20 MHz	< 5 mVrms, 20 V voltage source, 1 A resistive load			

[1] Example of calculating accuracy: To test the accuracy of a 120 mV output in the 600 mV range, the tolerance is:

$$\pm \left(\underbrace{120}_{\text{reading}} \times 0.03\% + \underbrace{0.1}_{\text{offset}} \right) \text{ mV} = \pm 0.136 \text{ mV}$$

[2] This instrument has a potentially dangerous high voltage (±210 V) output to the HI / Sense HI / Guard terminals. To prevent electric shock, relevant safety precautions must be taken before powering on. Do not connect the Guard terminal to any output, including shorting it to the chassis ground or output LO, as this will damage the instrument.



Current Programming and Measurement Resolution/Accuracy

	Range	Resolution	Accuracy (1 Year) ± (% reading + offset)	Typical Noise (RMS) 0.1 Hz to 10 Hz
Current Accuracy	±3 A ^[3]	1 µA	0.03% + 2 mA	40 µA
	±1 A	100 nA	0.03% + 90 µA	7 µA
	±100 mA	10 nA	0.03% + 9 µA	600 nA
	±10 mA	1 nA	0.03% + 900 nA	60 nA
	±1 mA	100 pA	0.03% + 90 nA	6 nA
	±100 µA	10 pA	0.03% + 9 nA	700 pA
	±10 µA	1 pA	0.03% + 1 nA	80 pA
	±1 µA ^[4]	100 fA	0.03% + 200 pA	20 pA
	Temperature Coefficient	± (0.15 × accuracy)/°C (0 °C to 18 °C, 28 °C to 50 °C)		
Overshoot	< ±0.1% (Typical, Normal; Step is 10% to 90% range, full-scale, resistive load)			

[3] 3 A range is available only for pulse mode, with typical accuracy.

[4] A triaxial cable connection is recommended for low current measurement: Hi to the center conductor, Guard to the inner shield, and the outer shield to protective ground; LO to the center conductor, with the inner shield unconnected, and the outer shield to protective ground. The rated insulation voltage of the triaxial cable must be a minimum of 250 V.



Resistance Measurement Resolution/Accuracy (4-Wire)

	Range	Resolution	Default Test Current	Typical Accuracy (1 Year) ± (% reading + offset)
Resistance Measurement Accuracy	600 mΩ	100 nΩ	1 A	0.07% + 100 μΩ
	6 Ω	1 μΩ	100 mA	0.07% + 1 mΩ
	60 Ω	10 μΩ	10 mA	0.07% + 10 mΩ
	600 Ω	100 μΩ	1 mA	0.07% + 100 mΩ
	6 KΩ	1 mΩ	100 μA	0.07% + 1 Ω
	60 KΩ	10 mΩ	10 μA	0.07% + 10 Ω
	600 KΩ	100 mΩ	1 μA	0.08% + 100 Ω
	Temperature Coefficient	± (0.15 × accuracy)/°C (0 °C to 18 °C, 28 °C to 50 °C)		
Manual Current Source Resistance Measurement (4-Wire)	<p>Total Error = Measured Voltage / Current Source Set Current = Resistance Reading × (Voltage Source Range Gain Error Percentage + Ammeter Range Gain Error Percentage + Current Source Range Offset Error / Set Current) + (Voltage Source Range Offset Error / Set Current Value)</p> <p>Example: Current Source Set Current = 1 A, Voltage Measurement Range = 600 mV</p> <p>Total Error = (0.03% + 0.03% + 90 μA / 1 A) + (100 μV / 1 A) ≈ 0.07% + 100 μΩ</p>			



Pulse Source Specifications

Item	Specification
Minimum Programmable Pulse Width	100 μ s
Pulse Width Programming Resolution	1 μ s
Pulse Width Programming Accuracy	± 10 μ s
Pulse Width Jitter	2 μ s
Pulse Width Definition	The time from 10% leading to 90% trailing edge as follows

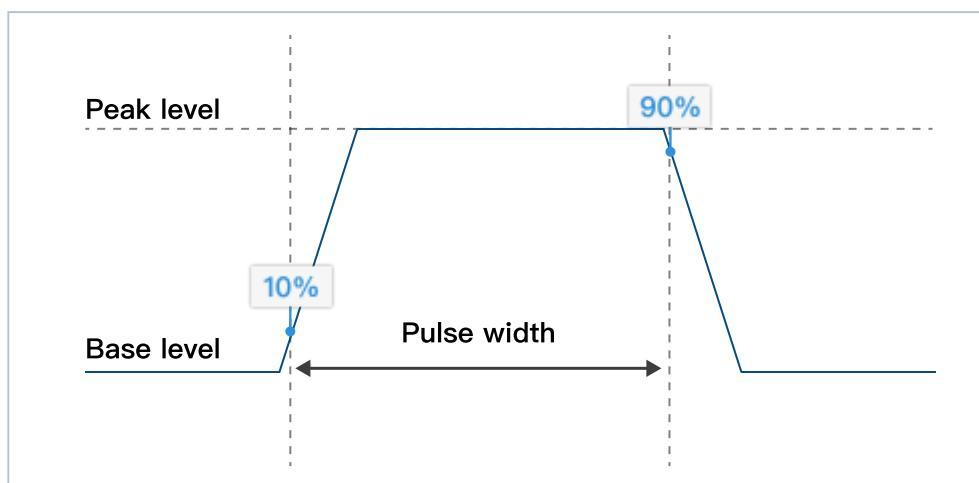

Pulse Width Definition

Maximum Current Limit	Maximum Pulse Width	Maximum Duty Cycle
0.1 A/200 V	DC, no limit	100%
1 A/20 V	DC, no limit	100%
3 A/66.6 V	1 ms	5%
3 A/160 V	400 μ s	2%



Pulse Source Rise Time

Output	Maximum Output	Typical Rise Time ^[5]	Typical Settling Time ^[6]	Test Load
Voltage Source	160 V	800 μ s	1.2 ms	No load
	5 V	50 μ s	100 μ s	No load
Current Source	3 A to 1 mA	90 μ s	250 μ s	Full load ^[7]
	100 μ A to 10 μ A	150 μ s	400 μ s	Full load ^[7]
	1 μ A	800 μ s	1.2 ms	Full load ^[7]

[5] Time required for the pulse leading edge to rise from 10% to 90%.

[6] Time required for the pulse to reach within 1% of final value.

[7] Test conditions: Normal mode, resistive full load, voltage rises to 6 V.



Output Settling Time

Output	Range	Output Settling Time ^[8]			Condition
		Fast ^[9]	Normal	Slow	
Voltage	200 V	< 600 μ s	< 1.2 ms	< 2 ms	Time required to reach within 0.1% of final value at open load condition. Step is 10% to 90% range.
	20 V	< 80 μ s	< 150 μ s	< 800 μ s	
	6 V	< 60 μ s	< 100 μ s	< 300 μ s	
	0.6 V	< 60 μ s	< 60 μ s	< 60 μ s	
Current	3 A to 1 mA	< 100 μ s	< 180 μ s	< 0.8 ms	Time required to reach within 0.1% (0.3% for 3 A range) of final value under Normal mode at full load with the voltage output rising to 6 V. Step is 10% to 90% range.
	100 μ A to 10 μ A	< 150 μ s	< 250 μ s	< 0.8 ms	
	1 μ A	< 1 ms	< 1 ms	< 1 ms	

[8] Output slew rate: Fast, Normal, Slow modes. Users can adjust APFC parameters according to load characteristics to achieve appropriate settling time or stability.

[9] Fast mode may exhibit significant output overshoot under different ranges or load conditions. For devices sensitive to overshoot, Normal or Slow mode is recommended.

Sampling Rate and NPLC Setting

Setting	Range
NPLC	0.00005 PLC to 10 PLC
Sampling Rate	5 sps to 1 Msps



Measurement Accuracy Derating

Add % of range using the following table for measurement with PLC < 1.

PLC	Range							
	600 mV	6 V	20 V	200 V	1 μ A	10 μ A	100 μ A to 100 mA	1 A to 3 A
0.1	0.02%	0.01%	0.01%	0.01%	0.02%	0.01%	0.01%	0.01%
0.01	0.3%	0.3%	0.03%	0.02%	0.2%	0.04%	0.02%	0.02%
0.001	3.2%	3.2%	0.4%	0.1%	2.5%	0.4%	0.03%	0.03%

Environmental Specifications

Item	Specification
Environment	For use in indoor facilities
Operating	0 °C to +50 °C, 30% to 60% RH, non-condensing
Storage	-30 °C to 70 °C, 10% to 90% RH, non-condensing
Dimensions	210 x 130 x 20 mm
Weight	Net weight: 0.46 kg
Power Supply	Full Load: 12 V/3.5 A; 3.3 V/0.5 A; 5 V/0.01 A
Altitude	Operating: 0 m to 2000 m, Storage: 0 m to 4600 m
Pollution Degree	2
Warm-Up	1 hour



4 Ordering Information

Standard Factory Accessories: Output connector (cable not included), Digital I/O connector (cable not included), Installation Software USB Drive (PC software and product driver, PDF product datasheet, PDF user manual).

Model Number	
S2013C	Precision SMU
Options	
TA-01001	Output Extension Connector, 250 V, 1 A, 4 W, Triaxial
Consumables/Accessories	
TA-03001	Triaxial Output Cable, Male-to-Male, 0.6 m, 250 V, 1 A
TA-03002	Triaxial Output Cable, Male-to-Male, 1.5 m, 250 V, 1 A
TA-03003	Triaxial Output Cable, Male-to-Male, 4 m, 250 V, 1 A
Service	
R3C	Factory Extended Warranty Service Plan – 36 Months
R5C	Factory Extended Warranty Service Plan – 60 Months



5 Warranty

No.	Item	Content	Warranty Period
1	Main Unit	Free repair within warranty	12 months
2	Options	Consumables and accessories are not covered under warranty	3 months
3	Calibration Interval	Factory calibrated or calibrated at the nearest Semight service center	12 months



Contact us

Semight Instruments Co., Ltd.

E-mail

sales@semight.com

Address

No.315, Taishan Road, Suzhou New District, Jiangsu, China

Website

For more information, please visit www.semight.com

*Product specifications and descriptions herein are subject to change without notice.

